



HF-Regulator II for TL-D lamps

HF-R 158 TL-D EII 220-240V 50/60Hz

Flat, lightweight high-frequency electronic regulating ballast, using 1-10V protocol for TL-D fluorescent lamps

Product data

| General Information | |
|--|---|
| Remarks | UK importer address: Signify Commercial UK Limited, 3, Guildford Business Park, GU2 8XG |
| Application code | EII |
| Type version | mk2 |
| Lamp type | TL-D |
| Number of lamps | 1 piece/unit |
| Number of products on MCB (16 A type B) (nom.) | 28 |
| Automatic restart | Yes |
| Operating and Electrical | |
| Input Voltage | 220 to 240 V |
| Input frequency | 50 to 60 Hz |
| Operating frequency (max.) | 105 kHz |
| Operating frequency (min.) | 45 kHz |
| Ignition method | Programmed Start |
| Crest factor (max.) | 1.7 |
| Power factor 100% load (nom.) | 0.97 |
| Ignition time (max.) | 0.2 s |
| Mains voltage performance (AC) | -8% - +6% |
| Mains voltage safety (AC) | -10% - +10% |

| | |
|------------------------------|---------|
| Earth leakage current (max.) | 0.5 mA |
| Inrush current width | 0.25 ms |
| Power losses (nom.) | 6.3 W |
| Inrush current peak (max.) | 27 A |
| Efficiency at full load [%] | 90.66 % |

| Wiring | |
|--|--|
| Connector type input terminals | WAGO 251 universal connector [Suitable for both automatic wiring (ALF and ADS) and manual wiring] |
| Connector type output terminals | WAGO 251 universal connector [Suitable for both automatic wiring (ALF and ADS) and manual wiring] |
| Connector type control input terminals | WAGO 251 universal connector [Suitable for both automatic wiring (ALF and ADS) and manual wiring] |
| Wire strip length | 8.0-9.0 mm |
| Dual fixture master/slave | Not applicable [Master/Slave oper. not applicable] |
| Control input terminal cross section | 0.50-1.00 mm ² |
| Input terminal cross section | 0.50-1.00 mm ² |
| Output terminal cross section | 0.50-1.00 mm ² |

HF-Regulator II for TL-D lamps

| | |
|--|--------------------------------|
| Auto-insert (ALF/ADS) wire cross section | 0.5 mm ² |
| System characteristics | |
| Rated ballast-lamp power | 58 W |
| Temperature | |
| T-ambient (max.) | 50 °C |
| T-ambient (min.) | -20 °C |
| T storage (max.) | 80 °C |
| T storage (min.) | -25 °C |
| Stable lamp operation temperature | Not Specified |
| T-ignition (max.) | 50 °C |
| T-ignition (min.) | 0 °C |
| Controls and Dimming | |
| Control interface | 1-10V |
| Regulating level power | 1%-100% |
| Control input protection | Yes (Basic insulation) |
| Mechanical and Housing | |
| Housing | L 360x30x21 |
| Emergency Operation | |
| Battery voltage lamp ignition | 196 V |
| Battery voltage lamp operation | 154-276 |
| Approval and Application | |
| Energy efficiency index | A1 BAT |
| IP classification | IP 20 [Ingress Protection 20] |

| | |
|------------------------------------|---|
| EMI 9 kHz ... 30 MHz | EN55015 |
| EMI 30 MHz ... 1,000 MHz | EN55022 level B |
| Safety standard | IEC 61347-2-3 |
| Performance standard | IEC 60929 |
| Quality standard | ISO 9000:2000 |
| Environmental standard | ISO 14001 |
| Harmonic current emission standard | IEC 61000-3-2 |
| EMC immunity standard | IEC 61547 |
| Vibration standard | IEC68-2-6 F c |
| Bumps standard | IEC 68-2-29 Eb |
| Humidity standard | EN 61347-2-3 clause 11 |
| Approval marks | CE marking ENEC certificate VDE-EMV certificate |
| Temperature marking | Yes |
| Emergency standard | IEC 60598-2-22 |
| Humming and noise level | Inaudible |

Product Data

| | |
|-----------------------------------|------------------------------------|
| Full product code | 871150091017230 |
| Order product name | HF-R 158 TL-D EII 220-240V 50/60Hz |
| EAN/UPC – product | 8711500910172 |
| Order code | 91017230 |
| Local order code | HFR158TLDII |
| SAP numerator – quantity per pack | 1 |
| Numerator – packs per outer box | 12 |
| SAP material | 913700609466 |
| SAP net weight (piece) | 0.270 kg |

Dimensional drawing

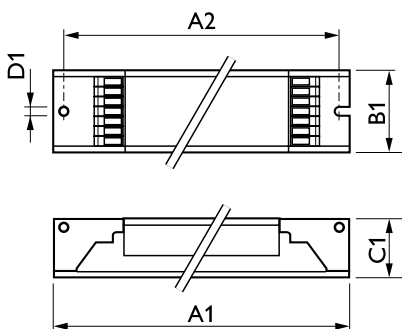

HF-R 158 TL-D EII 220-240V 50/60Hz

| Product | D1 | C1 | A1 | A2 | B1 |
|------------------------------------|--------|-------|--------|--------|-------|
| HF-R 158 TL-D EII 220-240V 50/60Hz | 4.2 mm | 22 mm | 360 mm | 350 mm | 30 mm |

HF-Regulator II for TL-D lamps

